

Werkzeugkatalog

tool catalogue

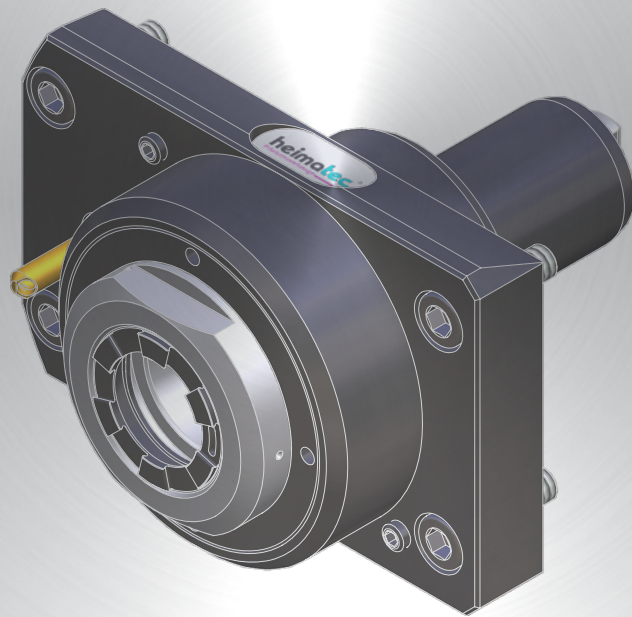

Yamazaki Mazak

Quick Turn Smart 300 M
Quick Turn Smart 350 M



Hinweis zu den AGBs:

Diese finden Sie in unserem Internetauftritt unter

www.heimatec.de

Home/Impressum/AGB

Terms and conditions:

You will find them on our website

www.heimatec.com

Home/Imprint/Terms and Conditions

Das Katalog-Werk einschließlich aller seiner Teile ist urheberrechtlich geschützt. Jede Verwertung außerhalb der engen Grenzen des Urheberrechtsgesetzes ist ohne Zustimmung der Rechteeinhaber unzulässig und strafbar. Das gilt insbesondere für Vervielfältigungen, Übersetzungen, Mikroverfilmungen und die Einspeicherung und Verarbeitung in elektronischen Systemen.

heimatec® GmbH behält sich Änderungen technischer Art jederzeit ohne Vorankündigung vor. Dies gilt insbesondere bei Anpassungen an neue oder geänderte internationale Normen oder bei Weiterentwicklungen unserer Produkte oder Herstellungsprozesse.

This catalogue, including all its parts, is protected by copyright. Each use outside the restricted limitations of the Copyright Act is inadmissible and liable to prosecution without the consent of heimatec. This is particularly valid for duplication, translation, microfilming and feeding and processing in electronic systems.

heimatec® GmbH reserves the right of technical changes everytime without advance notice, which is particularly valid for adaptations to new or changed international standards, or to developments of our products or manufacturing processes.

angetriebene Werkzeuge driven tools



Axial-Bohr- und Fräskopf axial drilling and milling head

Kombilagerung / combi bearing
 $n_{max} = 4000 \text{ min}^{-1}$

| | | | |
|--------------|-----------------|-----------|-----|
| 8 010 77 002 | ER 40 AX u-tec | EK | 1:1 |
| 8 010 77 003 | ER 40 AX u-tec | IK 25 bar | 1:1 |
| 8 010 77 006 | ER 40 AX u-tec | IK 70 bar | 1:1 |
| 8 010 78 003 | easy-quick HT 6 | EK | 1:1 |
| 8 010 78 004 | easy-quick HT 6 | IK 25 bar | 1:1 |
| 8 010 78 006 | easy-quick HT 6 | IK 70 bar | 1:1 |



Axial-Bohr- und Fräskopf axial drilling and milling head

Spindellagerung / spindle bearing
 $n_{max} = 6000 \text{ min}^{-1}$

| | | | |
|--------------|-----------------|-----------|-----|
| 8 010 77 004 | ER 40 AX u-tec | EK | 1:1 |
| 8 010 77 005 | ER 40 AX u-tec | IK 25 bar | 1:1 |
| 8 010 77 008 | ER 40 AX u-tec | IK 70 bar | 1:1 |
| 8 010 78 007 | easy-quick HT 6 | EK | 1:1 |
| 8 010 78 008 | easy-quick HT 6 | IK 25 bar | 1:1 |
| 8 010 78 009 | easy-quick HT 6 | IK 70 bar | 1:1 |



Winkel-Bohr- und Fräskopf radial drilling and milling head

Mittenmaß / center distance $H=100$
Kombilagerung / combi bearing
 $n_{max} = 4000 \text{ min}^{-1}$

| | | | |
|--------------|-----------------|------------|-----|
| 8 030 77 002 | ER 40 AX u-tec | EK | 1:1 |
| 8 030 77 003 | ER 40 AX u-tec | IK 140 bar | 1:1 |
| 8 030 78 008 | easy-quick HT 6 | EK | 1:1 |
| 8 030 78 009 | easy-quick HT 6 | IK 140 bar | 1:1 |



Winkel-Bohr- und Fräskopf radial drilling and milling head

Mittenmaß / center distance $H=100$
Spindellagerung / spindle bearing
 $n_{max} = 6000 \text{ min}^{-1}$

| | | | |
|--------------|-----------------|------------|-----|
| 8 030 77 005 | ER 40 AX u-tec | EK | 1:1 |
| 8 030 77 006 | ER 40 AX u-tec | IK 140 bar | 1:1 |
| 8 030 78 010 | easy-quick HT 6 | EK | 1:1 |
| 8 030 78 011 | easy-quick HT 6 | IK 140 bar | 1:1 |

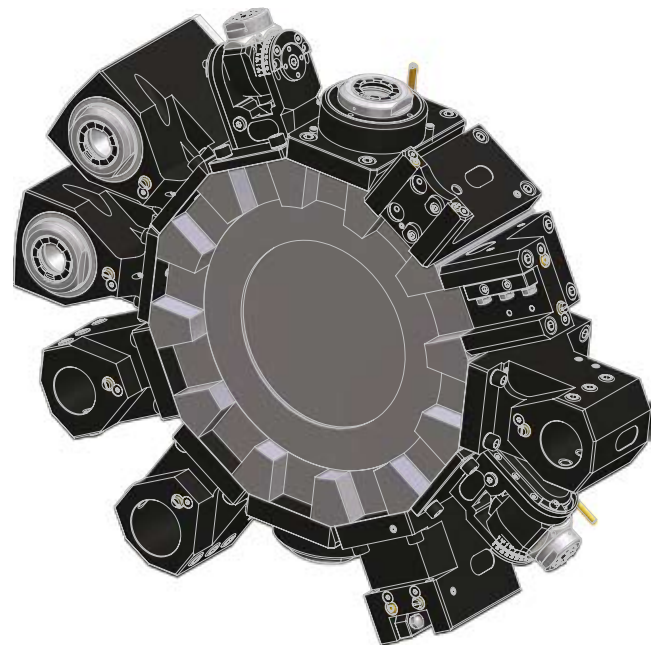

Schwenkkopf universal head

Mittenmaß / center distance $H=80$
 $n_{max} = 6000 \text{ min}^{-1}$

| | | | |
|--------------|----------------|------------|-----|
| 8 040 75 001 | ER 25 AX u-tec | EK | 1:1 |
| 8 040 75 002 | ER 25 AX u-tec | IK 140 bar | 1:1 |

festе Werkzeuge
static tool holders

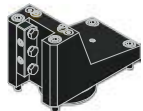

Kombi-Drehstahlhalter
universal turning holder

| | | |
|--------------|----------------------------------|----|
| 8 214 75 002 | Vierkant/square 25 | EK |
| 8 214 75 003 | Vierkant/square 25,4 (1") | EK |

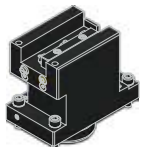

Kombi-Plandrehhalter
combi facing holder

Mittenmaß / center distance H=105

| | | |
|--------------|----------------------------------|----|
| 8 234 75 004 | Vierkant/square 25 | EK |
| 8 234 75 005 | Vierkant/square 25,4 (1") | EK |



Bohrstangenhalter
boring bar holder

Mittenmaß / center distance H=120

| | | |
|--------------|--------------------|-------|
| 8 230 79 003 | ø 40 | IK/EK |
| 8 230 79 000 | ø 50 | IK/EK |
| 8 230 79 002 | ø 60 | IK/EK |
| 8 230 79 001 | ø 50,8 (2") | IK/EK |



Abstechhalter
cut-off holder

| | | |
|--------------|--------------|----|
| 8 214 73 000 | SH 32 | EK |
|--------------|--------------|----|

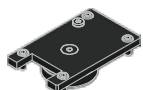

Abdeckplatte
cover plate

| | | |
|--------------|--|--|
| 8 200 75 000 | | |
|--------------|--|--|

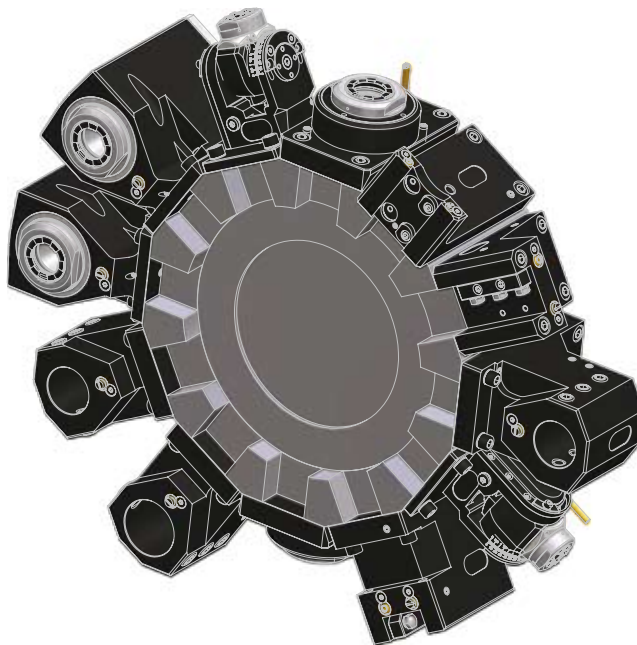

Mazak Quick Turn Smart 300 M / 350 M

▶ Weitere Ausführungen auf Anfrage
further versions on request

▶ Zubehör ZB...*
accessories ZB...*



▶ easy-quick



▶ u-tec



Hauptsitz/headquarters

heimatec® GmbH
Präzisionswerkzeuge
Carl-Benz-Straße 4
D- 77871 Renchen
Postfach 11 36
D- 77867 Renchen
Tel.: +49 (78 43) 94 66 0
Fax: +49 (78 43) 94 66 66
www.heimatec.de
info@heimatec.de

heimatec® Inc.
16 E. Piper Lane Suite 121
USA- 60070 Prospect Heights IL
Tel.: +1 (847) 749 0633
Fax: +1 (847) 749 2445
www.heimatecinc.com
info@heimatecinc.com

heimatec® - Ost, JSC
ul. Kozjubinskogo 4 office 209
RUS- 121351 Moskau
Tel.: +7 (495) 648 69 19
Fax: +7 (495) 648 69 19
www.heimatec-ost.ru
sales@heimatec-ost.ru

